



# GPS-PS1E

## GPS RECEIVER MODULE

### DATA SHEET

---



---

GPS Receiver Board based on SiRFstar™ I/LX



<b>Title</b>	<b>GPS-PS1E</b>
<b>Doc Type</b>	DATA SHEET
<b>Doc Id</b>	GPS.G1-PS1-00002-B
<b>Author :</b>	Patrik Eggenberger
<b>Date :</b>	9. Jan 02
For most recent documents, please visit <a href="http://www.u-blox.com">www.u-blox.com</a>	

We reserve all rights in this document and in the information contained therein. Reproduction, use or disclosure to third parties without express authority is strictly forbidden.

All trademarks mentioned in this document are property of their respective owners.

SiRF and the SiRF logo are registered trademarks of SiRF Technology, Inc. SiRF Powered, SiRFstar, SiRFLoc, SiRFDive, SiRFNav, SiRFWare, SingleSat, SnapLock, SnapStart, FoliageLock, Push-to-Fix, TricklePower and WinSiRF are trademarks of SiRF Technology, Inc.

Copyright © 2002, u-blox ag

THIS DATASHEET CONTAINS INFORMATION ON U-blox PRODUCTS IN THE SAMPLING AND INITIAL PRODUCTION PHASES OF DEVELOPMENT. THE SPECIFICATIONS IN THIS DATASHEET ARE SUBJECT TO CHANGE AT U-blox' DISCRETION. U-blox ASSUMES NO RESPONSIBILITY FOR ANY CLAIMS OR DAMAGES ARISING OUT OF THE USE OF THIS DATASHEET, OR FROM THE USE OF MODULES BASED ON THIS DATASHEET, INCLUDING BUT NOT LIMITED TO CLAIMS OR DAMAGES BASED ON INFRINGEMENT OF PATENTS, COPYRIGHTS OR OTHER INTELLECTUAL PROPERTY RIGHTS. U-blox MAKES NO WARRANTIES, EITHER EXPRESSED OR IMPLIED WITH RESPECT TO THE INFORMATION AND SPECIFICATIONS CONTAINED IN THIS DATASHEET. PERFORMANCE CHARACTERISTICS LISTED IN THIS DATASHEET ARE ESTIMATES ONLY AND DO NOT CONSTITUTE A WARRANTY OR GUARANTEE OF PRODUCT PERFORMANCE.

# CONTENTS

<b>1</b>	<b>Features .....</b>	<b>4</b>
<b>2</b>	<b>Overview .....</b>	<b>5</b>
<b>3</b>	<b>Product Line-up .....</b>	<b>6</b>
<b>4</b>	<b>GPS Performance Specification.....</b>	<b>7</b>
4.1	GPS accuracy .....	7
4.2	Start-up times .....	7
<b>5</b>	<b>Operating Modes .....</b>	<b>9</b>
5.1	Normal Operation .....	9
5.2	TricklePower™ Operation .....	9
5.3	Customized Operation.....	9
<b>6</b>	<b>Technical Specifications .....</b>	<b>10</b>
6.1	Electrical Specifications .....	10
6.1.1	Absolute Maximum Ratings .....	10
6.1.2	Operating Conditions .....	10
6.2	Pin Description .....	11
6.2.1	Serial Interface Signals .....	11
6.2.2	Special Power Pins.....	12
<b>7</b>	<b>How to Make it Run .....</b>	<b>13</b>
<b>8</b>	<b>Mechanical Specifications.....</b>	<b>14</b>
<b>A</b>	<b>Related Documents.....</b>	<b>17</b>
<b>B</b>	<b>Contact.....</b>	<b>17</b>

# 1 FEATURES

- Full Implementation of the SiRFstar™ I/LX Architecture, Including:
  - GRF1/LX Low-power RF front-end IC
  - GSP1/LX Low-power GPS DSP with Integrated Real Time Clock (RTC)
  - Hitachi RISC CPU SH-7020
  - 1 MBit SRAM
  - 4 MBit FLASH memory
  - Low Noise Amplifier
  - Filter, Crystals, etc.
- SiRFstar™ I/LX TricklePower™ enhanced power management modes (3 stage)
- Differential GPS (RTCM-SC 104) input
- Dimensions: 82.5mm × 32mm × 8.5mm
- M/A-Com SSMT coax connector for RF-Input or standard SMB
- Bias Voltage for active antenna 4.75V
- 2 bi-directional Serial Interfaces
- Operating voltage 5 Volts
- Industrial operating temperature range (−40 - +85°C)
- External requirements:
  - 5 Volt power supply, 0.75 Watt (max.)
  - Backup battery for real time clock and SRAM
  - Serial interface for NMEA or SiRF<sup>®</sup> binary data
  - Passive or active Antenna

Customer specific code can be implemented on the Hitachi SH-1 processor using the u-blox Software Customization Kit.

## 2 OVERVIEW

GPS-PS1E is a fully self-contained receiver module for the Global Positioning System (GPS). Based on the SiRFstar™ I/LX chip set manufactured by SiRF Technology, Inc., the module supports all features, and maintains the technical specifications of the SiRFstar™ I/LX architecture.

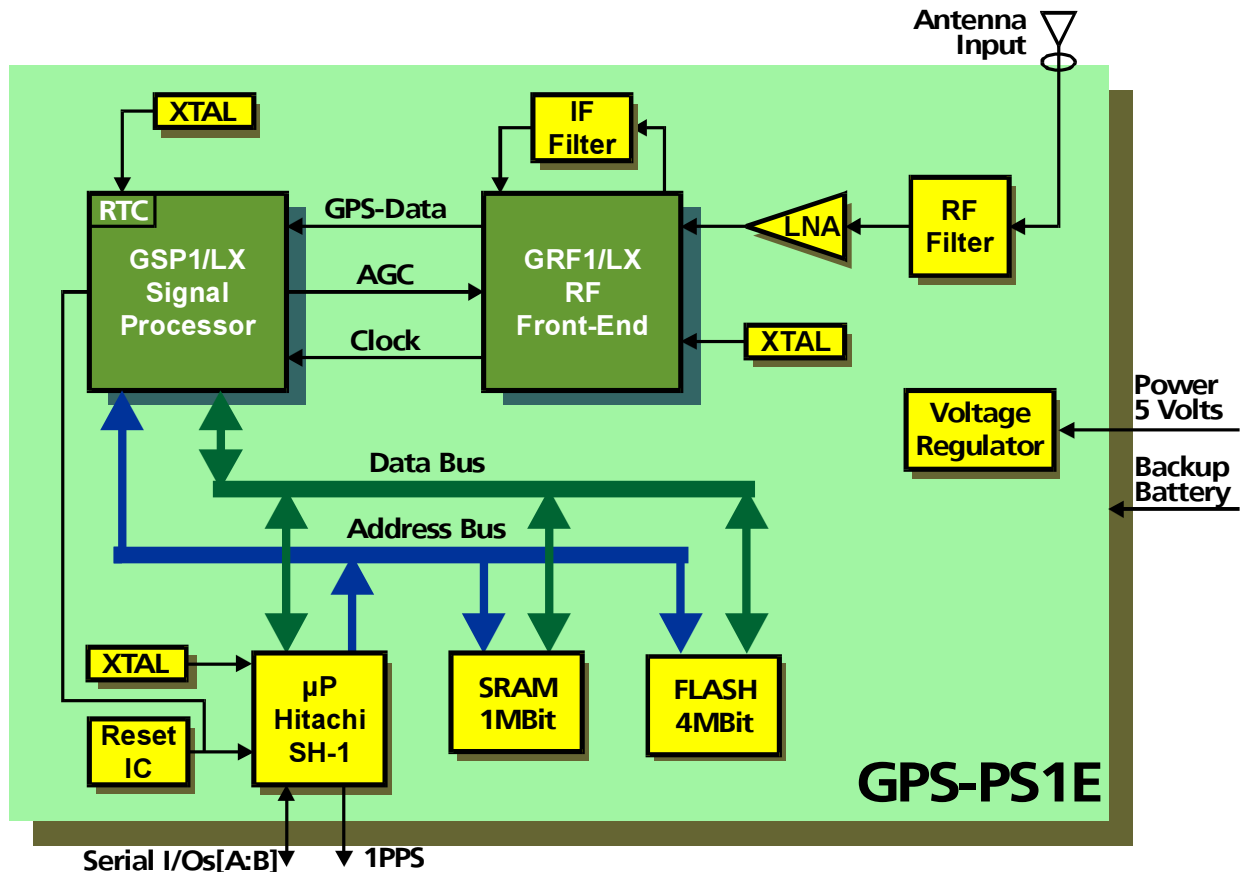

Figure 1: Blockdiagram of GPS-PS1E

The module, which is 82.5mm × 32mm in size, provides complete GPS signal processing from antenna input to serial data output (NMEA or SiRF<sup>®</sup> proprietary data format). A second serial port accepts differential GPS data (RTCM).

The receiver runs at an external operating voltage of 5 Volts. Internally this is converted to the operating voltage of 3.3 Volts, so the module consumes less than 0.75 Watts in continuous operation mode. The implementation of the patent pending TricklePower™ Mode allows an additional drastic reduction of power consumption for applications where power consumption is of primary concern (see also the *Low Power Mode Application Note*). Using a third crystal the GPS-PS1E offers extended TricklePower™ Mode capabilities. It can shut off the RF part of the module independently from the processor. The GPS-PS1E is fully backward compatible to the GPS-PS1.

Featuring the GRF1/LX RF front-end chip and an integrated Low-Noise Amplifier (LNA), the module connects seamlessly to low-cost passive antennas. Active antennas can be connected to the GPS-PS1E as well. An antenna bias voltage (4.75V) is internally generated. Sufficient CPU power of the module's Hitachi SH-1 RISC CPU allows the integration of additional customer specific functionality. For many applications, the functionality of an external micro-controller can be transferred to GPS-PS1E. The u-blox Software Customization Kit is required to change the firmware or implement additional functionality on the on-board microprocessor.

### 3 PRODUCT LINE-UP

The standard GPS-PS1E is supplied in the following start-up configuration:

- SiRF<sup>®</sup> binary protocol
- 19'200 Baud
- 8 data bits, no parity, 1 stop bit

During a firmware up-date the default start-up configuration of the receiver can be set. Firmware up-dates as well as the up-date utility are available at the u-blox homepage. See the *Firmware Up-date Manual* for further information.

Refer to Table 1 for ordering information. Options are available in higher quantities.

Option	Features
None	Standard version with M/A-Com SSMT/OSMT antenna connector
S	SMB antenna connector instead of SSMT/OSMT
DL	Adds datalogging capability

**Table 1: Ordering Options**

For the GPS-PS1E an integrated datalogger is available as an ordering option. This option enables the user to take advantage of the on-board FLASH memory to store position data.

Ordering example:

**GPS-PS1E-S-DL**          GPS-PS1E with datalogger and SMB connector.

## 4 GPS PERFORMANCE SPECIFICATION

### 4.1 GPS accuracy

GPS receiver accuracy is a function of GPS receiver performance, satellite constellation and Selective Availability (SA). GPS accuracy is not properly defined. Every manufacturer has its own means of defining, measuring and calculating position accuracy.

We define commonly used measures and give the values for all of them in the *GPS receiver performance application note*. In Table 1 we focus on CEP, which gives the most intuitive feel for the accuracy of a GPS receiver.

**Definition of Circular Error Probability:** The radius of a circle, centered at the antenna's true position, containing 50 % of the fixes.

See *GPS receiver performance application note* for more details.

### 4.2 Start-up times

A GPS receiver knows different start-up scenarios, which differs significantly in the Time-to-first-fix (TTFF). These start-up scenarios depend on the amount of knowledge the GPS receiver has regarding its positions and the availability of satellites. Just like GPS accuracy, startup times for GPS receivers are another field where every manufacturer has its own naming scheme, and therefore, comparison between receivers is difficult. In the following a short introduction in our definitions of start-up times (see Table 3 for specifications) is given. Please note that these numbers were measured with good visibility (open view to the sky). Obstructed view will result in longer start-up times.

#### Definitions:

**Cold Start** In Cold Start Scenario, the receiver has no knowledge on last position, approximate time or satellite constellation. The receiver starts to search for signals blindly. This is standard behavior, if no backup battery is connected. Cold Start time is the longest startup time for u-blox GPS receivers.

**Warm Start** In Warm Start Scenario, the receiver knows - due to a backup battery – his last position, approximate time and almanach. Thanks to this, it can quickly acquire satellites and get a position fix faster than in cold start mode.

**Hot Start** In Hot Start Scenario, the receiver was off for less than 2 hours. It uses its last Ephemeris data to calculate a position fix.

**Reacquisition** The reacquisition figure gives the time required to get lock on a satellite if the signal has been blocked for a short time (e.g. due to buildings). This is most important in urban areas. Reacquisition time is not related with TTFF.

Parameter	Specification	
Receiver Type	L1 frequency, C/A Code, 12-Channel	
Max Up-date Rate	1Hz	
Accuracy (SA off)	Position	5m CEP
Accuracy (SA on)	Position Time	21m CEP +/- 180ns
Accuracy (DGPS)	Position Time	2m CEP +/- 60ns
Acquisition (typical)	Cold Start Warm Start Hot Start	60 sec 45 sec 2 - 6 sec
Signal Reacquisition	100 ms	
Dynamics	<= 4g	
Operational Limits	Altitude <60000ft and velocity <1000 knots Either limit may be exceeded but not both (COCOM restrictions)	

Table 2: GPS receiver specifications



## 5 OPERATING MODES

GPS-PS1E can be operated in different operating modes.

### 5.1 Normal Operation

In Normal Mode, the module is continuously running as long as the operating voltage Vcc is supplied. Position fixes are generated at the maximum update rate. An external backup battery must be connected to enable the module to keep the internal Real Time Clock running and to hold the SRAM data (ephemeris and almanac data) during power supply interruption. Use of an external backup battery is recommended to reduce the system's startup time. However, under good visibility conditions cold- and warm start times do not differ significantly.

### 5.2 TricklePower™ Operation

In TricklePower™ Mode, Vcc is continuously supplied to the module. A software configurable internal timer periodically forces the module to acquire a position fix. Between the fixes, the module remains in an ultra-low power sleep mode. This mode is recommended for applications where lowest power consumption and a periodical position up-date are of primary concern. A backup battery must be connected to enable the module to reduce startup times when recovering from a Vcc supply interruption. The GPS-PS1E supports a new enhanced TricklePower™ Mode. This enables to shut off the CPU independently from the RF part. So in TricklePower™ Mode operation there are 3 Modes: Track Mode (RF and CPU on), CPU Mode (CPU on) and Standby Mode (RF off, CPU in stand-by).

State	Current (typ.) <sup>1</sup>
Track Mode	140 mA
CPU Mode	34 mA
Standby Mode	0.25 mA

**Table 3 : TricklePower™ Mode states**

The RF on time (Track Mode) depends on the length of the up-date period. The CPU on time (CPU Mode) depends also on the number of satellites in view. (See *Low Power Mode Application Note* for more details).

The currents during the different states are given in Table 3. This means that the power supply must be capable of delivering at least 140mA at 5V, regardless of the average current drawn by the module in TricklePower™ Mode.

During the TricklePower™ mode the firmware periodically schedules ephemeris collection and RTC calibration to insure that useable data is always available. Ephemeris collection occurs once within a 30 minutes period and whenever a new satellite rises above the horizon. Collecting ephemeris data every 30 minutes for 18 seconds is equivalent to running the full receiver (140 mA) for an extra 10ms at a one second up-date rate.

The power-on scenario in TricklePower™ Mode differs from the one in continuous Mode. If the module fails to acquire 3 satellites within a given time (due to bad visibility or very low signal levels) the module goes into an extended sleep phase. The length of this sleep phase is defined by the duty cycle (up-date rate). After this period the module wakes up and tries to acquire a position fix again.

For more detailed information on TricklePower™ Mode please check the *Low Power Mode Application Note*.

### 5.3 Customized Operation

The Hitachi SH-7020 RISC-CPU provides enough computational power to allow the implementation of additional customer specific software into the module. In order to implement software on the on-board processor the Software Customization Kit (GPS-SCK) is required. The Software Customization Kit includes a development platform (compiler) and a sub-license of the firmware on the receiver. Contact u-blox for a detailed discussion of the feasibility of implementing a particular application.

<sup>1</sup> Excluding Antenna Power (depends on the type of active antenna)

## 6 TECHNICAL SPECIFICATIONS

### 6.1 Electrical Specifications

#### 6.1.1 Absolute Maximum Ratings

Parameter	Symbol	Min	Max	Units
Power Supply Voltage	V <sub>cc</sub>	-0.3	16	V
Input Pin Voltage	V <sub>in</sub>	-0.3	6	V
Antenna Bias Current	I <sub>ant</sub>		300	mA
Storage Temperature	T <sub>stg</sub>	-55	125	°C

**Table 4: Absolute Maximum Ratings**

Stressing the device beyond the “Absolute Maximum Ratings” may cause permanent damage. These are stress ratings only.



GPS-PS1E is not protected against overvoltage or inverse voltages. If necessary, voltage spikes exceeding the power supply voltage specification, given in table above, must be reduced by using appropriate protection diodes.

#### 6.1.2 Operating Conditions

Parameter	Symbol	Min	Typ	Max	Units
Power Supply Voltage	V <sub>cc</sub>	4.5 <sup>1</sup>	5.0	5.5	V
Power Supply Voltage Ripple	V <sub>cc_ripple</sub>		100		mV
Backup Battery Voltage	V <sub>bat</sub>	2.0		3.6	V
Input Pin Voltage	V <sub>in</sub>	0		V <sub>cc</sub>	V
Antenna Bias Voltage (no load)	V <sub>ant</sub>	4.63	4.7	4.77	V
Antenna bias voltage drop @50 mA	V <sub>ant_drop</sub>		0.45		V
Supply Current	I <sub>cc</sub>		140 <sup>2</sup>		mA
TricklePower™ Sleep Mode Supply Current	I <sub>tps</sub>		0.25		mA
Standby Battery Current @V <sub>bat</sub> =3.6V (T=25°C)	I <sub>bat</sub>		20		µA
Standby Battery Current @V <sub>bat</sub> =3.3V (T=25°C)	I <sub>bat</sub>		8		µA
Standby Battery Current @V <sub>bat</sub> =3.0V (T=25°C)	I <sub>bat</sub>		6		µA
Antenna Bias Voltage Current	I <sub>ant</sub>			50	mA
Operating Temperature	T <sub>opr</sub>	-40		85	°C

**Table 5: Operating Conditions**

Operation beyond the “Operating Conditions” is not recommended and extended exposure beyond the “Operating Conditions” may affect device reliability.

<sup>1</sup> Without active antenna, with active antenna 4.9 V

<sup>2</sup> Not including current consumption of the active antenna (typ ~25mA)

## 6.2 Pin Description

Please see Table 6 for the pin identification for the 2 connectors of the GPS-PS1E.

Pin	Type	Name
1	O	TX_B
2	I	Vcc
3	O	TX_A
4	I	Vbat
5	I	RX_A
6	O	TIMEMARK
7	I	RX_B
8	I	GND

Table 6: Pin Identification CON A

Pin	Type	Name
1		NC (reserved)
2		NC (reserved)
3		NC (reserved)
4	I/O	RESET
5		NC (reserved)
6		NC (reserved)
7	O	Vcc 3.3V
8	I	Test_I

Table 7: Pin Identification CON B

### 6.2.1 Serial Interface Signals

All serial interface signals TX\_A, RX\_A, TX\_B and TX\_B operate on 3.3V CMOS compatible signal levels. The inputs RX\_A and RX\_B are 5V tolerant. The outputs are also 5V TTL compatible. If RS-232 compatible signal levels are required an external driver (e.g. MAX232) must be provided.

Default operation includes sending out SiRF<sup>®</sup> binary data format compatible position data on Serial Port A and accepting RTCM SC-104 differential correction data on Serial Port B. NMEA 0183 position data format can optionally be used instead of SiRF<sup>®</sup> binary data format. See the *u-blox GPS receiver protocol specifications* for detailed information on the serial protocols.

The configuration of the receiver can also be changed by using the SiRF<sup>®</sup> binary communication protocol. In order to change the default start-up configuration of the receiver, the firmware on the receiver has to be updated. During this up-date the default start-up configuration is set.

Unused Serial Input Ports should be left open.

Port	Baud Rate
A and B	4800
	9600
	19200 (default)
	38400

Table 8: Available Baud rates

Using SiRF<sup>®</sup> binary protocol, the lowest baud rate that can be achieved is 9600. Because of the limited bandwidth with 9600 baud development data and raw data can only be transmitted at 19200 baud. NMEA protocol allows using baud rates down to 4800, depending on the messages used. Special Function Signals

A **1PPS**<sup>4</sup> signal is available at the timemark pin. This signal is 3.3V CMOS and 5V TTL compatible.

### 6.2.2 Special Power Pins

A DC-bias voltage for an active antenna is supplied internally. Typically, the voltage required by an active antenna is 4.5V or 5V. The bias voltage supplied by the GPS-PS1E is 4.7V.



Some passive antennas are shorts from a DC point of view. Connecting such a passive antenna will damage the GPS-PS1E.

An external backup battery must be connected to pin **Vbat** to enable RTC operation and SRAM backup and to allow GPS warm or hot starts after power supply interruption.

Pin	Signals	Description
<b>Serial I/O</b>		
1,3,5,7	TX_A, RX_A, TX_B, RX_B,	Serial I/O ports. In default configuration, GPS data is output on port A, DGPS data is input on port B.
<b>Special Functions</b>		
6	TIMEMARK	1 pulse per second (1PPS) signal of GPS-PS1E.
<b>Power Pins</b>		
2	Vcc	5V Supply Voltage
8	GND	Module Ground
4	Vbat	Backup voltage supply for RTC and SRAM. Connect to GND, if not used.

Table 9: GPS-PS1E Signal Description

<sup>4</sup> 1 pulse-per-second

## 7 HOW TO MAKE IT RUN

The following are the minimum outside connections one has to provide to allow basic operation of GPS-PS1E. If you plan to use more of GPS-PS1E's functionality within your application, please contact u-blox support.

1. **Antenna** Use a cable fitted with M/A-Com SSMT coaxial connector to connect the antenna to the module (see Table 10). For the GPS-PS1E-S version use a SMB connector.
2. **Power** Connect Vcc pin 2 to 5V. And, connect GND pin 8 to ground. No special decoupling capacitors are necessary. The power supply should be capable of delivering a sustained current of at least 150 – 170 mA, depending on the power consumption of the active antenna. A proper RESET signal is internally generated.
3. **Serial Interface** Pins 1,3,5 and 7 (RX\_[A:B] and TX\_[A:B]) are 3.3V CMOS compatible. The RX inputs are also 5V tolerant. The TX outputs are also 5V TTL compatible. If you need different voltage levels, use appropriate level shifters. E.g. in order to obtain RS-232 compatible levels use the 3V compatible MAX232 from Maxim or equivalent. GPS data will come out of port A. You can use port B to feed in DGPS correction data.
4. **Backup Battery** Connect a backup battery to pin 4 (Vbat) if you intend to use this feature. You can also use a supercap. The voltage at this pin can be anywhere between 2.0V and 3.6V. For charging of the supercap, connect its positive pole through a diode to Vcc. If you don't intend to use a backup battery, connect this pin to GND.

**1PPS Signal** On pin 6 (TIMEMARK), a one-pulse-per-second signal is available.

# 8 MECHANICAL SPECIFICATIONS

Figure 2 shows the mechanical dimensions of the module.

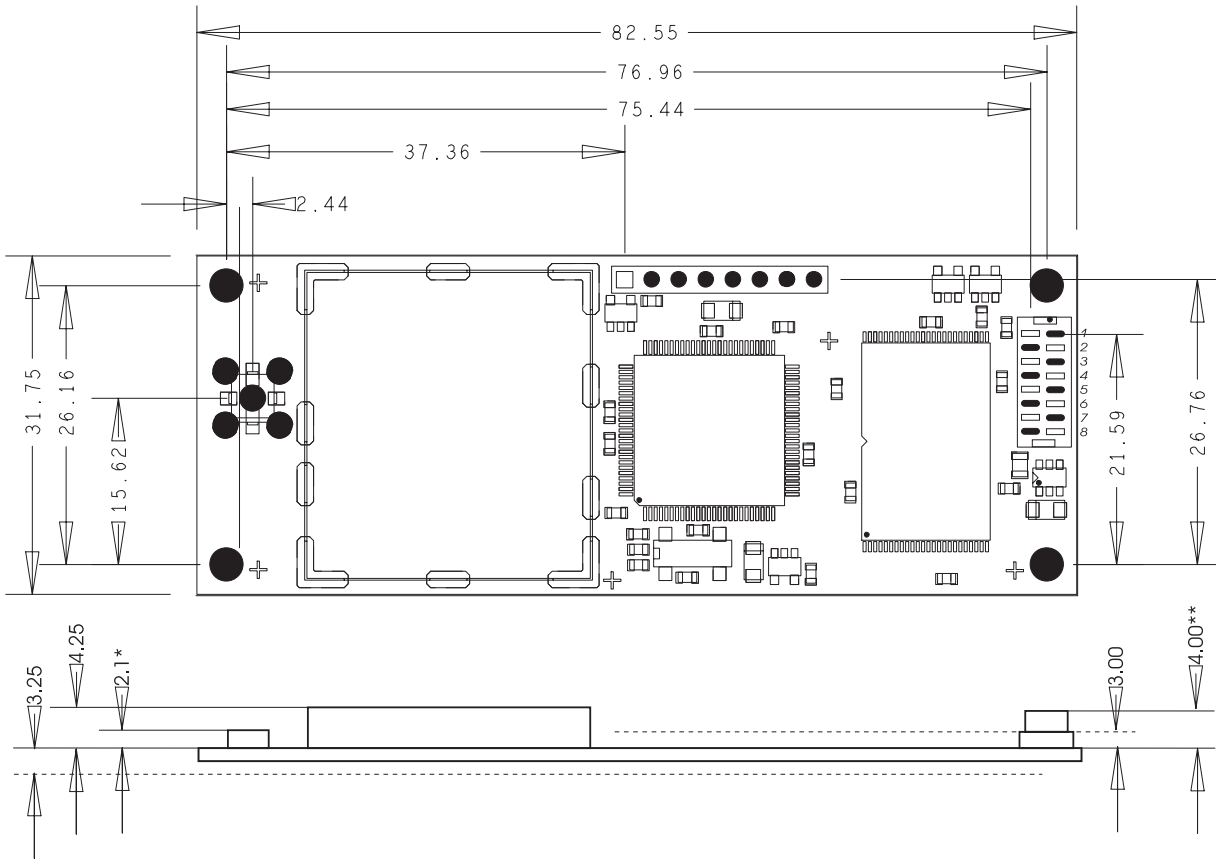

\* Mated Height 3.2  
 \*\*Mated Height 6

All Dimensions in mm

**Figure 2: Mechanical Dimensions GPS-PS1E (with M/A-Com SSMT connector)**

The weight of the module is approximately 13<sup>±</sup> grams including the metal shield. See Table 10 for matching RF connectors for the GPS-PS1E.

Connector on module	Matching Connector
AMP MicroMatch 215079-8	Ribbon connector AMP215083-8
M/A-COM SSMT plug receptable	M/A-COM SSMT/OSMT Right Angle Jack Pigtail Part Number 9960-2100-24
M/A-Com SSMT plug receptable	M/A-COM SSMT/OSMT to SMA cable assembly (100mm) P/No 9960-4100-02
SMB connector male (S option) IMS 81.1524.201	SMB connector female

**Table 10: Matching Connectors**

Check URL below for more information:

M/A-COM RF-Connectors: WWW: <http://www.macom.com>

IMS RF connectors (SMB)

AMP MicroMatch Series WWW: <http://www.amp.com>

<sup>±</sup> 16 grams with SMB connector (GPS-PS1-S)

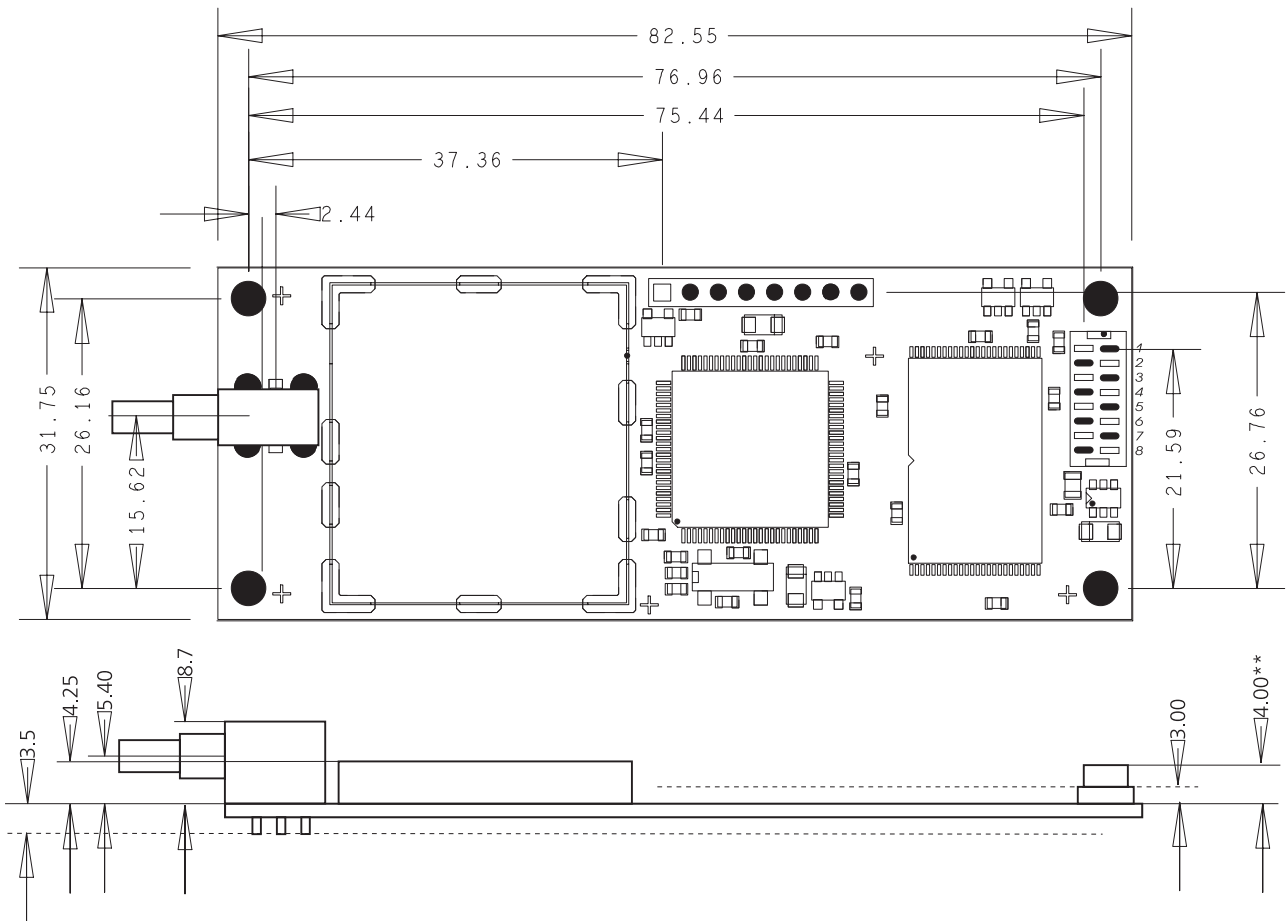

\*\*Mated Height 6

All Dimensions in mm

Figure 3: Mechanical Dimensions GPS-PS1E-S (with SMB connector)

**Footprint GPS-PS1**

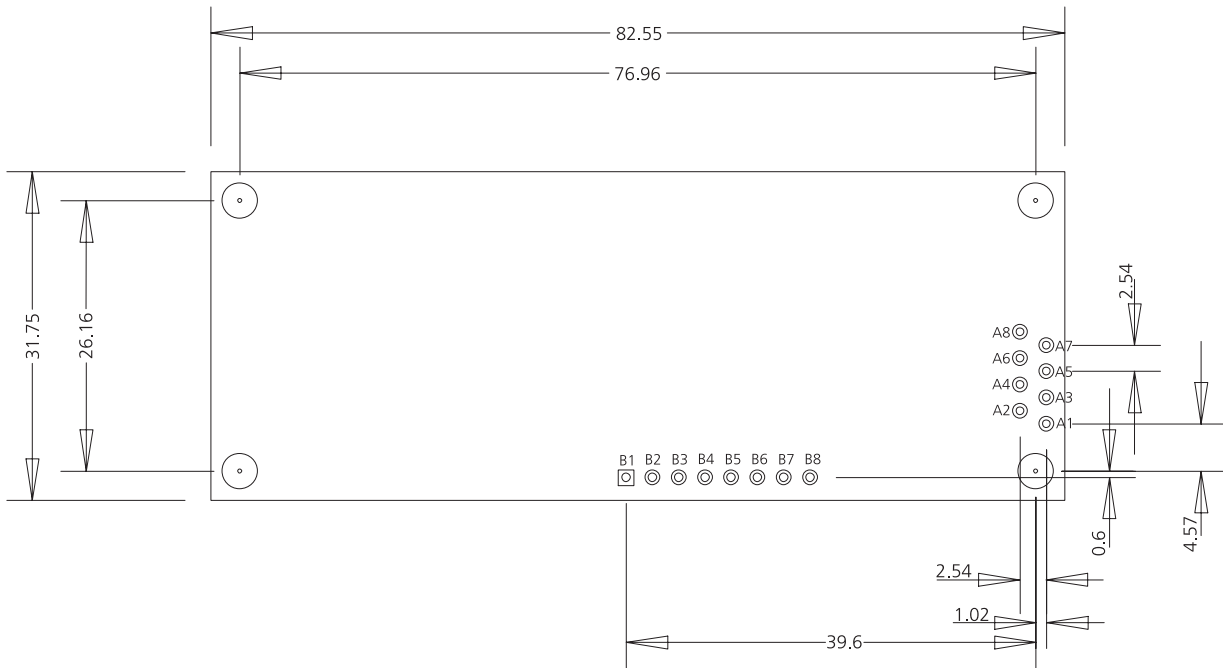

**Figure 4: Recommended Footprint**



## A RELATED DOCUMENTS

- [GPS-xS1 Protocol Specification](#)
- [Logging Option on u-blox GPS receivers](#)
- [Performance of u-blox GPS receivers](#) Application Note
- [GPS-xS1 Firmware Update Manual](#)

All these documents are available on our homepage (<http://www.u-blox.com>).

## B CONTACT

For further info, please contact us:

Headquarters	Subsidiaries	
<p><b>u-blox ag</b> Zuercherstrasse 68 CH-8800 Thalwil Switzerland</p> <p>Phone: +41 1 722 74 44 Fax: +41 1 722 74 47 E-mail: <a href="mailto:info@u-blox.com">info@u-blox.com</a> <a href="http://www.u-blox.com">www.u-blox.com</a></p>	<p><b>u-blox Deutschland GmbH</b> Berliner Ring 89 D-64625 Bensheim Germany</p> <p>Phone: +49 (0) 6251 17566-0 Fax: +49 (0) 6251 17566-11 E-mail: <a href="mailto:info_de@u-blox.de">info_de@u-blox.de</a> <a href="http://www.u-blox.de">www.u-blox.de</a></p> <p><b>Tech. Support:</b> Phone: +41 1 722 74 74 <a href="mailto:support_de@u-blox.de">support_de@u-blox.de</a></p>	<p><b>u-blox Asia Pacific Ltd.</b> 22/F., City Landmark I 68 Chung On Street Tsuen Wan, Hong Kong</p> <p>Phone: +852-2941-8877 Fax: +852-2615-2285 E-mail: <a href="mailto:info_ap@u-blox.com">info_ap@u-blox.com</a> <a href="http://www.u-blox.com">www.u-blox.com</a></p> <p><b>Tech. Support:</b> Phone: +41 1 722 74 74 <a href="mailto:support_ap@u-blox.com">support_ap@u-blox.com</a></p>
	<p><b>u-blox Europe Ltd.</b> Barham Court Maidstone, Kent ME18 5BZ United Kingdom</p> <p>Phone: +44 1622 618628 Fax: +44 1622 618629 E-mail: <a href="mailto:info_uk@u-blox.co.uk">info_uk@u-blox.co.uk</a> <a href="http://www.u-blox.co.uk">www.u-blox.co.uk</a></p> <p><b>Tech. Support:</b> Phone: +44 1622 618628 <a href="mailto:support_uk@u-blox.co.uk">support_uk@u-blox.co.uk</a></p>	<p><b>u-blox America, Inc.</b> 13800 Coppermine Road Herndon, VA 20171 USA</p> <p>Phone: +1 (703) 234 5290 Fax: +1 (703) 234 5770 E-mail: <a href="mailto:info_us@u-blox.com">info_us@u-blox.com</a> <a href="http://www.u-blox.com">www.u-blox.com</a></p> <p><b>Tech. Support:</b> Phone: +1 (703) 234 5290 <a href="mailto:support_us@u-blox.com">support_us@u-blox.com</a></p>

# Revision History

<b>Revision Index</b>	<b>Date</b>	<b>Name</b>	<b>Status / Comments</b>
-	29.6.99	PE	Draft
A	12.11.01	GzB / PB	Trademarked and reformatted
B	9.1.02	GH / PE	Preliminary removed